

T100 Power Trainer Quick-start Guide

Magene-T100

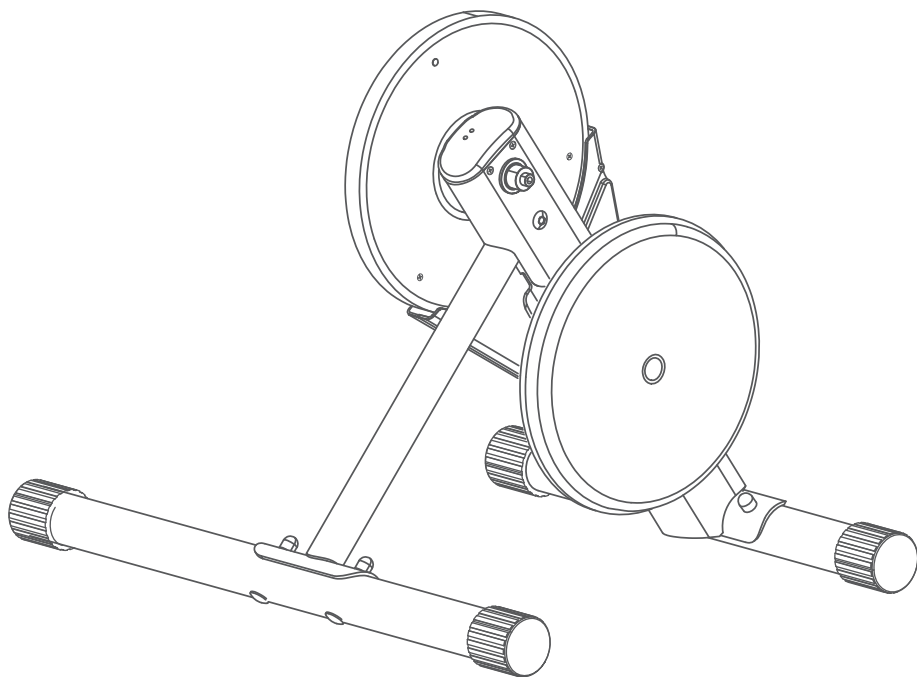

01 Quick Start Guide

Thank you for purchasing the T100 Power Trainer. Please read the instructions carefully before using the product. Feel free to contact us if you have any questions or concerns:

- Email: sales@magene.cn
- Website: <https://magenefitness.com>
- After-sales service: support@magene.cn

02 Unboxing

Remove the T100 Power Trainer and all accessories from the box and be sure to keep the original box for subsequent transportation and storage. In case of warranty repairs and returns, be sure to use the original packaging. Otherwise the Company will not bear any responsibility for any loss caused during transportation. If the packing box and foam are missing, please contact the local dealer or service personnel.

- ① T100 Power Trainer ② Quick release lever
③ Quick Release Dropout Converter ④ Cassette Converter Washer

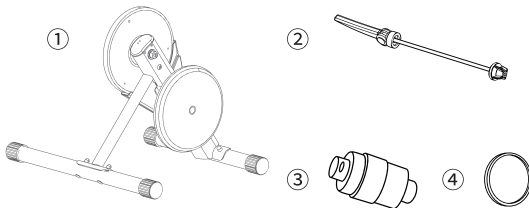

NOTE:

- 1.T100 Power Trainer is as shown on the left.The user needs to prepare any parts not included in the packaging.
- 2.Two Triple-A battery are needed for T100 Power Trainer,please purchase and install them follow the steps of 7.2
- 3.A axle (sold separately) is required to mount a bike with drum shaft components.

03 Installation

Please follow the instructions to use the product.

The description of any accessories (such as flywheels, axle.) below is only for the purpose of explaining how to use the product as only those included in the packing list come with the product.

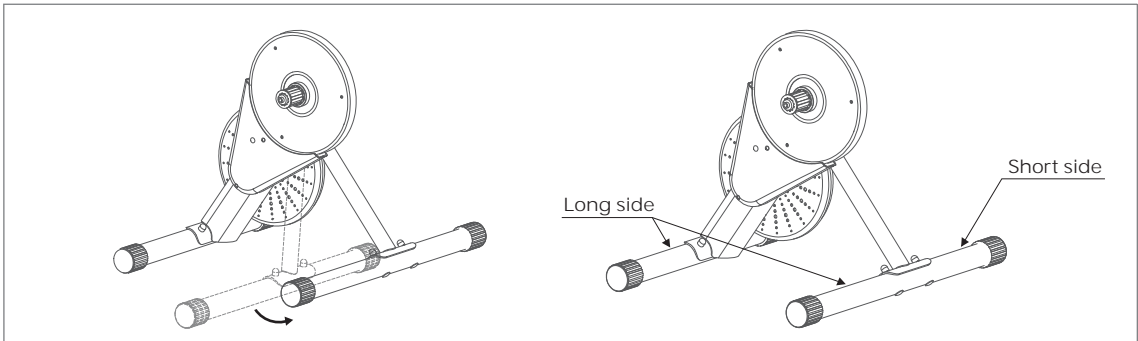
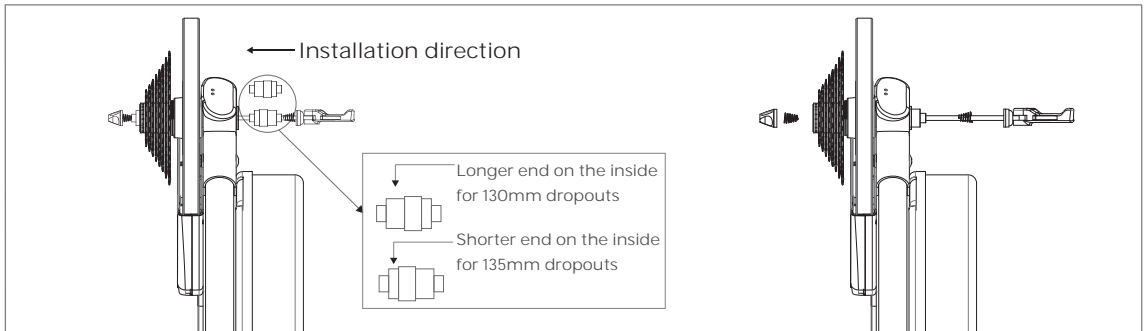

Fig 1 Trainer installation

1. Place the T100 Power Trainer on a flat and stable surface and ensure that there are no obstacles or dangerous objects near the product.
2. Pull the movable legs to the maximum extent and make sure that the product sits firmly without wobble.
3. Install batteries or rotate the pulley to activate the trainer, at which time the LED indicator will flash slowly.



Note The axle set is for sold separately.

Fig 2 Quick release installation

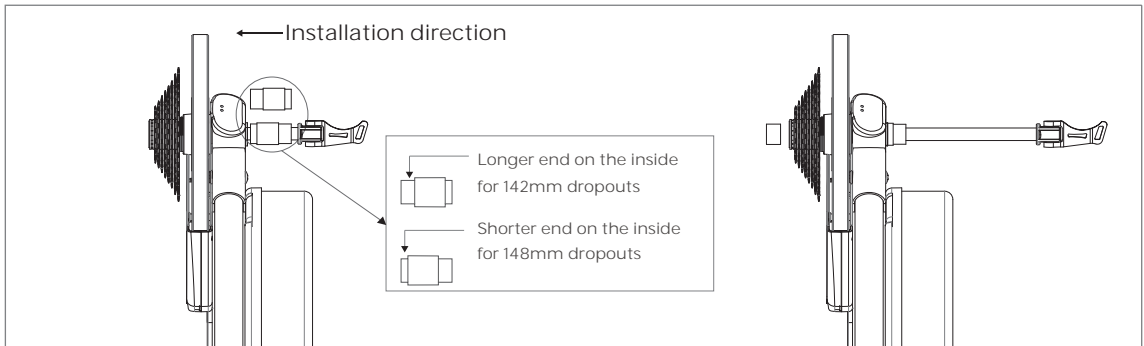

Fig 3 Axle installation

4. The T100 Power Trainer is compatible with cassette flywheels produced by Shimano and SRAM, including 11-speed flywheels (direct installation) and 8 9 10-speed flywheels (requiring flywheel baskets). Campagnolo transmission users can also install a Shimano cassette flywheel on the trainer.

Please use dedicated installation tools when installing flywheels.

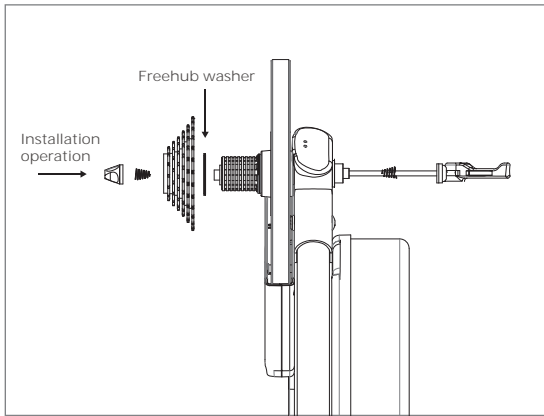

Fig 4 Quick release installation operation

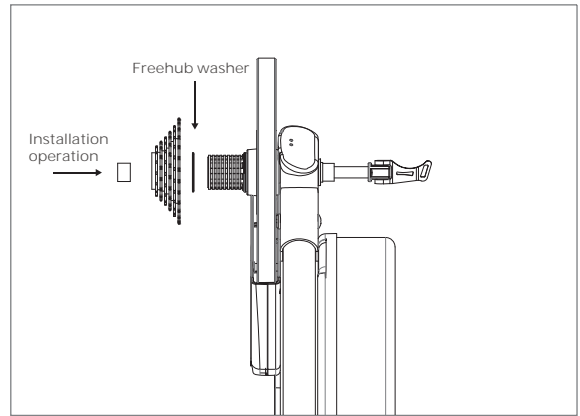

Fig 5 Axle installation operation

04 Installation of the bicycle

1. Fit the bike chain to the smallest front and rear flywheel and remove the rear wheel of the bike.
2. To install a bike on the product, first align the bike chain with the smallest flywheel on the T100 Power Trainer, then press it until the fork end is fully fixed on the product's axle.
3. Push the quick release lever to the OPEN position and push the product firmly against the inside of the bike's bottom.
4. Use your left hand to slowly tighten the adjustment nut clockwise while using your right

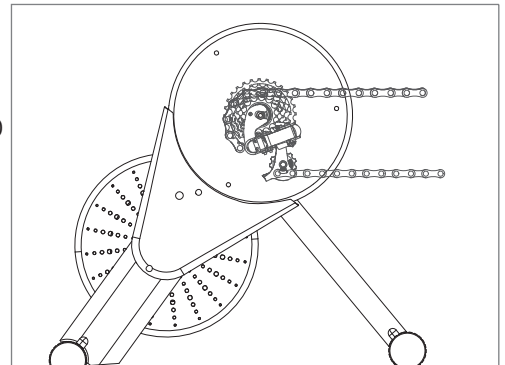

Fig 6 Installation of the bicycle

hand to open and close the quick release lever. Continue tightening the nut until you can feel the resistance from the lever when it reaches a position parallel to the hub.

5. Hold the bike frame with your hand and push the quick release lever with your palm until it is fully tightened, at which point the word "CLOSE" on the lever should face outward and the level should be in front of or parallel to the fork legs.

6. Note! If the Quick Release lever is not correctly tightened, it may cause property loss or personal injury. If it is hard to attain proper tightness, please consult your local bicycle store or contact MAGENE. Please do not adjust the Quick Release lever while cycling.

05 Connection to T100 Power Trainer

The LED indicator flashes slowly when installing a battery or turning pulley on this product, at which point you can connect the product to your device via wireless ANT + Bluetooth. When the connection is established, the LED will stop flashing and remain turned on, indicating that the operation is successful.

- T100 Power Trainer supports Zwift and other third-party software.
- An ANT receiver (sold separately) is required to connect the T100 Power Trainer with a PC.
- Smart power trainer may not be listed as an option in some third-party training software or code table, in which case you can try to search by the keyword "power meter".

06 Activation and Spin-down Calibration

Note! Each new product must be activated before first use.

Please go to www.magenefitness.com to download the Magene Utility to activate the power trainer;

Better Spin-down Calibration will be acquired after warming-up for 10 minutes.

In order to ensure power calculation accuracy, it is recommended to perform a despin calibration after training with T100 Power Trainer for a pro-longed period.

07 Indicator light and Battery Installation

T100 Power Trainer has two indicator lights, one ① for system status and the other ② for communication status. See the figure for placement of the two indicators.

7.1 LED Indicator

Status	Indication	
Battery exhausted	LED off	
Trainer in sleeping mode		
Low power mode		
Normal operation	No Bluetooth connection	the LED flashes slowly
	Bluetooth connected	the LED is always on
Low power	Red light flashes every 10 seconds	
Spin-down Calibration	Red / blue LED flashes alternately, and blue light keeps on after successful Calibration	

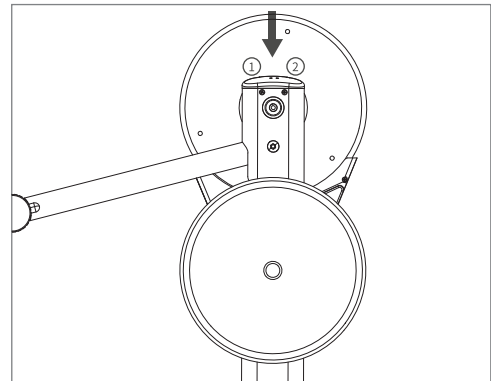

Fig 7 LED Indicator

7.2 Battery Installation

Before using, you should install two triple-A batteries by following the procedures below:

1. Use the cross screwdriver to release the screw fixing the control module in the arrow direction shown.
2. Remove the control module and Install two triple-A batteries.
3. Reset the control module, then tighten the fixing bolt to complete battery replacement.

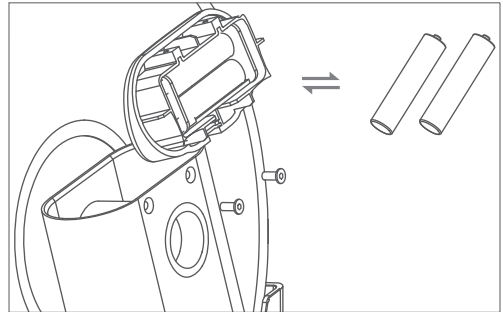

Fig 8 Battery Installation

NOTE!

- If the battery is exhausted, you need to replace it by following the procedure above.
- Used dry batteries should be discarded immediately.
Never try to disassemble the batteries.
- If the product will not be used for a long time, remove the batteries to avoid battery leakage which may cause damage to the product.

08 Warnings!

- Keep children and pets away from the T100 Power Trainer during use.
- Place T100 Power Trainer on a flat, stable surface before using it and consult your doctor before starting and changing any workout plan.
- Do not touch any moving part of the T100 Power Trainer with your hands or objects.
- Beware that the rear flywheel will become very hot after using the T100 Power Trainer for a long time, make sure not to touch it.

- Do not try to disconnect the bike while flywheel is spinning.
- Be careful when riding with the T100 Power Trainer in a standing position.
- Keep the T100 Power Trainer away from sources of fire, water and other obstacles.
- For any user who weighs more than 85Kg, it's recommended not to swing your body from left to right while riding with the product in a standing position, otherwise there is the danger of overturning or frame fracture.

09 Warranty Card

Warranty Clauseproduct :

Thank you for purchasing the T100 Power Trainer. To ensure that the product warranty takes effect, please fill out this card after carefully reading the terms below and preserve it for safekeeping.

Warranty Clause :

- This product has passed strict quality inspection. According to the description of this warranty card, if any product quality issue occurs in normal usage during the warranty period, the user can enjoy free repair service.
- Within 7 days from the date of purchase(including),the quality of the product itself is unconditionally returned.
- The product warranty period is 365 days (or other length of time as required by local law), starting from the date of sale (or the date of shipment (activation) if there is no sale date).

- The user needs to use original packaging and the specified logistics/transportation method to send the product for free repair, otherwise the user should be held liable for freight or any damage caused by transportation.

The following situations are not covered by warranty:

- The product is out of warranty.
- Any damage caused by improper use, maintenance and storage.
- Damage caused due to not following instructions for product use and installation.
- Damage caused arbitrary repair, misuse, collision, negligence, abuse, fluid penetration, accident, modification or use of accessories not specified in the manual.
- Alteration of warranty certificate without authorization.
- The user can't provide valid warranty certificate and invoice.
- The product number or code shown on the warranty certificate does not match the actual product.
- Other malfunction and damage caused by problems other than product design, manufacturing, quality, etc.
- Abrasions, smudges and scratches that occur during normal use of the product, as well as damage caused by human-made accidents such as contact with chemical agents, sharp objects, and dropping, crushing.
- Damage caused by force majeure.

Term of after-sales service:

Term of after-sales service:

Refer to instructions on official website: www.magenefitness.com

After the warranty expires, repairs due to malfunctions require users to assume the cost of repair and shipping, while repairs due to artificial damage require users to assume the cost of labor, parts and transportation.

The Company retains the rights to modify and explain above-mentioned contents.

WARRANTY CARD

PRODUCT INFORMATION

Customer Name: _____

Address: _____

Purchase Date: _____

Distributor(Seal and Signature): _____

SERIVE RECORD

Service Date	Malfunction and Solution